

**920AS**
**головка торцевая, двенадцатигранная, дюймовая**

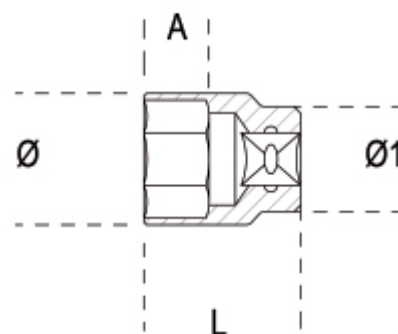

art.	art.	"	Ø mm	L mm	Ø1 mm	A mm	g
009200201	920AS 3/8	3/8	14,9	38	21,7	6,0	49
009200202	920AS 7/16	7/16	16,1	38	21,7	7,0	50
009200203	920AS 1/2	1/2	18,7	38	21,7	8,0	52,7
009200204	920AS 9/16	9/16	20,1	38	21,7	10,0	53,6
009200206	920AS 5/8	5/8	22,7	38	22,5	10,0	69,6
009200207	920AS 19/32	19/32	21,5	38	23,7	10,0	60,6
009200208	920AS 11/16	11/16	25,3	39	24,0	12,0	82
009200209	920AS 3/4	3/4	26,6	39	24,0	12,0	80,5
009200210	920AS 25/32	25/32	27,8	40	25,0	12,0	94,5
009200211	920AS 13/16	13/16	28,8	40	25,0	14,0	95,9
009200212	920AS 7/8	7/8	29,9	41	26,0	14,0	114,2
009200214	920AS 15/16	15/16	32,2	43	27,0	16,0	151
009200216	920AS 1	1	34,2	45	28,0	16,0	170
009200217	920AS 1.1/16	1.1/16	36,2	46	29,0	18,0	187
009200218	920AS 1.1/8	1.1/8	38,6	48	31,0	18,0	239
009200219	920AS 1.3/16	1.3/16	40,2	48	32,0	20,0	205
009200220	920AS 1.1/4	1.1/4	42,3	49	33,5	22,0	258