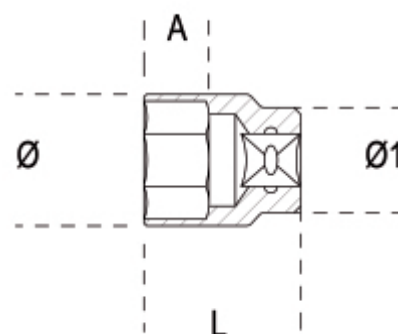

**910AS**
**головка торцевая, двенадцатигранная, дюймовая**

art.	art.	"	Ø mm	L mm	Ø1 mm	A mm	g
009100201	910AS 1/4	1/4	9,5	28	16,7	4,0	23
009100202	910AS 5/16	5/16	12,1	28	16,7	5,0	24
009100203	910AS 11/32	11/32	13,2	28	16,7	5,0	25
009100204	910AS 3/8	3/8	14,6	29	16,7	6,0	27
009100205	910AS 7/16	7/16	15,8	29	16,7	7,0	25,6
009100206	910AS 1/2	1/2	18,4	31	17,0	8,0	33
009100207	910AS 9/16	9/16	19,7	32	17,5	10,0	37
009100208	910AS 19/32	19/32	20,9	32	18,0	10,0	41
009100209	910AS 5/8	5/8	22,2	33	18,5	10,0	46,3
009100210	910AS 11/16	11/16	24,7	34	20,0	12,0	64
009100211	910AS 3/4	3/4	25,8	35	21,0	12,0	70
009100212	910AS 13/16	13/16	28,2	36	23,0	14,0	82,6
009100213	910AS 7/8	7/8	29,7	37	24,0	14,0	90,8